

---

ESL-24 Electric Grill

# Operator Manual



ESL-24 shown with  
optional pedestal mount



PARADISE GRILLS®

## ESL-24 Electric Grill Operator Manual October 2022

The content of this manual is the property of Paradise Grills International, Inc. All rights reserved. Any reproduction, in whole or in part, is strictly prohibited without express written consent of Paradise Grills International, Inc.

**Paradise Grills International, Inc.**  
640 Ocoee Business Pkwy, Suite #80  
Ocoee, FL 34761

800-604-2023

[www.paradisegrills.com](http://www.paradisegrills.com)  
[sales@paradisegrills.com](mailto:sales@paradisegrills.com)

**ATTENTION INSTALLER:** PLEASE LEAVE THESE INSTRUCTIONS WITH THE CONSUMER.

**ATTENTION CONSUMER:** PLEASE RETAIN THESE INSTRUCTIONS FOR FUTURE REFERENCE. You are responsible for checking updates and revisions available online at <http://www.paradisegrillsdirect.com/owners/>.

Serial number \_\_\_\_\_

(See grill rating plate for serial number)

Purchase date \_\_\_\_\_

### **WARNING**

- **FOR OUTDOOR USE ONLY!**
- **Observe all local codes and ordinances when installing this appliance. If no local codes are applicable, wire unit in accordance with the latest National Electrical Code, ANSI/NFPA 70, or the Canadian Electrical Code, CSA C22.1, whichever is applicable.**
- **DO NOT use grill with a damaged power cord. Electrical shock can occur with exposure to water or another liquid, causing serious bodily injury, death and/or property damage.**
- **Do not store or use gasoline or other flammable liquids or vapors in the vicinity of this or any other appliance.**

# Contents

<b>Safety Considerations</b>	<b>3</b>
Safety Symbols.....	3
Operational Warnings.....	3
<b>Specifications</b>	<b>5</b>
Grill Specifications.....	5
Customer Required Items.....	6
Outdoor Rated Electric Cord .....	6
Safety Equipment.....	6
Grill Covers .....	6
<b>Grill Island Preparation</b>	<b>7</b>
Clearances .....	7
Custom Island Construction .....	7
Planning Considerations.....	8
Custom Built Island Cut-outs.....	8
Grill Dimensions .....	9
<b>Grill Assembly</b>	<b>10</b>
Electrical Precautions .....	10
Unpack the Box .....	11
Install the Grill .....	12
Countertop Placement.....	12
Pedestal Installation (optional).....	12
Paradise Grills Grill Cart (optional).....	16
Island Installation (optional).....	18
Grill Setup.....	19
Basic Setup.....	19
Install Handles .....	22
Install Side Shelves .....	23
<b>Operating the Grill</b>	<b>25</b>
Warnings and Cautions.....	25
Normal Operation.....	26
Using the Grill .....	27
First Time Operation.....	27
Heating Element.....	27
<b>Cleaning and Maintenance</b>	<b>28</b>

Maintain your Grill .....	28
Stainless Steel Maintenance .....	28
Corrosive Environmental Conditions.....	29
Grill Exterior .....	29
Grill Interior.....	29
Cleaning the Drip Tray .....	30
Preventive Maintenance.....	30

**Parts Diagram** **31**

**Limited Manufacturer's Warranty** **32**

Limited Warranty .....	32
Warranty Claim Submission .....	33

# Safety Considerations

---

## Safety Symbols

Throughout this manual, important safety information will be highlighted and marked as **CAUTION**, **DANGER**, or **WARNING**.

	A potentially hazardous situation or unsafe practice which, if not avoided, may result in minor or moderate injury, or property damage.
	A potentially hazardous situation which, if not avoided, could result in death or serious injury, or property damage.
	An imminently hazardous situation which, if not avoided, will result in death or serious injury, or property damage.

---

## Operational Warnings

All users must read this entire manual before attempting to operate the grill. Follow these safety precautions every time the grill is used:

Do not immerse the ESL-24 Electric Grill in water.
This grill is for outdoor use only! Do not operate in a building, garage, an any other enclosed area.
Do not store or use gasoline or other flammable liquids or vapor in the vicinity of this or any other appliance.
Observe all local codes and ordinances when installing this appliance. If no local codes are applicable, wire unit in accordance with the latest National Electrical Code, ANSI/NFPA 70, or the Canadian Electrical Code, CSA C22.1, whichever is applicable.

Do not use grill with a damaged power cord. Electrical shock can occur with exposure to water or other liquids, causing serious bodily injury, death and/or property damage.

If the information in this manual is not followed exactly, a fire or electrocution may result, causing serious property damage, personal injury, and/or loss of life.

**CALIFORNIA PROPOSITION 65**

1. Combustible by-products produced when using this appliance contain chemicals known to the State of California to cause cancer, birth defects, or other reproductive harm.
2. This product contains chemicals, including lead and lead compounds, known to the State of California to cause cancer, birth defects or other reproductive harm.
3. For more information see [www.P65Warnings.ca.gov](http://www.P65Warnings.ca.gov)



Read the installation, operation, and maintenance instructions thoroughly before operating or servicing this equipment to reduce risk of electrocution, fire, burn hazard, or other injury.

All electrical installations, service, and repairs must be performed by a qualified technician or authorized service agent.

This grill is for single family/residential use only, and not intended for commercial or indoor use.

# Specifications

## Grill Specifications

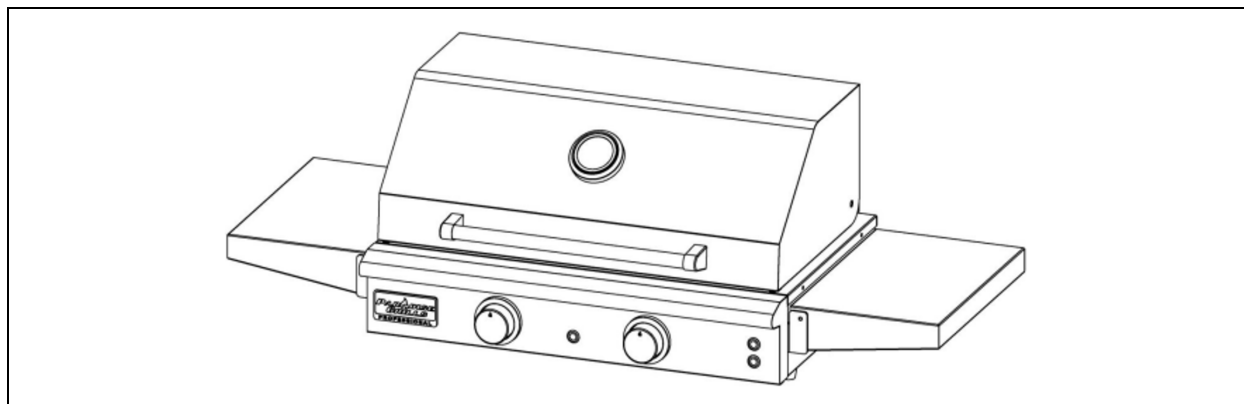

Cut-out Dimensions	24" W x 14 15/16" D x 5 5/8" H
Cooking Grate Dimensions	21" W x 11" D
Flame Tamer	Flame Stabilizer Grid with Ceramic Briquettes
Primary Ignition	Electric Element
Electrical Ratings	120V 60Hz 1540W
Warranty	<p><u>Limited Lifetime Warranty</u> on stainless steel housing to be free from original manufacturing defects.</p> <p><u>2 Year warranty</u> on cooking grate, flame tamers, and valves to be free from burn-through or original manufacturing defects.</p> <p><u>1 Year</u> warranty on heating element, heating element components, and lighting systems to be free from rust-through or original manufacturing defects.</p> <p>See Warranty section on page 32 for further details.</p>

---

## Customer Required Items

### Outdoor Rated Electric Cord

Your Paradise Grills Outdoor Kitchen electric grill is pre-wired with a GFCI electrical box installed. This electrical box has a hanging plug pigtail for connection to an existing GFCI electrical outlet for power supply. The customer must supply an outdoor-rated extension cord long enough to reach your chosen electrical outlet.

Use only a 12-gauge extension cord with a grounded, 3-prong plug. Outdoor extension cords should be used with outdoor products and are surface marked with suffix letter “W” and with a tag stating “Suitable for use with outdoor appliances.” The maximum length allowed for the extension cord is 25 feet. Do not use damaged extension cords. Examine extension cord before each use and replace if damaged. Keep cord away from heat and sharp edges.

### Safety Equipment

It is highly recommended to keep the following items close at hand whenever the grill is in use:

- Fire extinguisher, baking soda, sand, and/or kosher salt in case of a fire
- Grill gloves
- Long handled grill utensils

### Grill Covers

Grill covers are highly recommended. Protect your investment with our custom fit ESL Grill Cover, sold separately.

# Grill Island Preparation

---

## Clearances

Your grill island, regardless of the source, must be installed to ensure sufficient clearance from any combustible construction or materials. The customer is responsible for compliance with all local codes.

Heat rises when the grill is in operation. Covered locations (construction, overhang, or awning) should be avoided unless an outdoor vent hood is properly installed.

**Combustibles Materials:** Ensure your grill is located at least 16" from any combustible material such as wood, gyprock, paper and plants. Do not store combustible materials, gasoline, or flammable liquids or vapors anywhere in the vicinity of the grill. Ensure clearance from the grill to any combustible material is never less than 14" from sides and 16" from back. Follow all city and local codes.

### Overhead construction:

- Do not locate the grill under any unprotected, combustible overhead materials
- At least 6' clearance is required between the countertop and overhead construction unless an exhaust hood is used
- An exhaust hood is required if the grill is below unprotected combustible materials, and is highly recommended for any overhead construction
- When a vent hood is used, the coverage must be larger than the cooking surface of the grill, with a minimum of 1200 CFM air movement

---

## Custom Island Construction



This grill is for outdoor use only! Do not use this grill indoors under any circumstances.

Do not install or operate the grill in or on a recreational vehicle, trailer, boat, or any other moving installation.

## Planning Considerations

**Materials:** All grill islands must be constructed using only non-combustible materials. If any combustible materials are used, an insulated jacket must be added between the grill and the island.

**Airflow:** Proper airflow **MUST** be maintained for the grill to perform as it was designed. If airflow is blocked, overheating will result. Do not block more than 75% of the cooking grid surface with pans, aluminum foil, or other materials.

**Firm level surface:** Use your grill only on an outdoor, firm level surface. This grill is not designed for use within recreational vehicles, and should not be operated on a boat, marine craft, or other moving conveyance.

**Protection from weather:** Keep the grill protected from adverse weather, including rain and winds. Custom-fitted covers are available for purchase that have been specially designed for this grill.

**Partial enclosures:** Many backyards have areas that are partially closed off, such as balconies and pergolas. In some cases, it is difficult to decide whether these partially enclosed areas should be classified as indoor areas, particularly in terms of permanent (non-closable) ventilation. If you are in doubt, consult your local codes or a licensed contractor for guidance.

**Building permit:** Check with city and fire department for local building codes. A permit may be required for a custom-built grill island.

## Custom Built Island Cut-outs

Ensure any island cut-out opening is no larger than the outside frame of the appliance being installed. The appliance should rest on the lip of the frame.

The grill must be installed in a non-combustible enclosure only. The determination of whether a location is combustible or non-combustible construction is made by the local fire marshal, building inspector, or the local safety authority having jurisdiction.
To prevent overheating, do not obstruct the air flow of this appliance.

Here are some other considerations:

- Ensure your grill is adequately vented during operation. Consult your local licensed professional for adequacy requirements
- Ensure your outdoor kitchen is constructed out of non-combustible materials
- If your outdoor kitchen is constructed of any combustible materials, an insulated jacket is **REQUIRED**
- Cutout dimensions do not allow for lid clearance or other measurement requirements. See the [Install the Grill](#) section for specifics

- Please allow for a tolerance of +/- 1/8"; we recommend having your appliances in hand to measure before making final cutouts in your custom-built grill island

## Grill Dimensions

The ESL-24 dimensions as shown below:

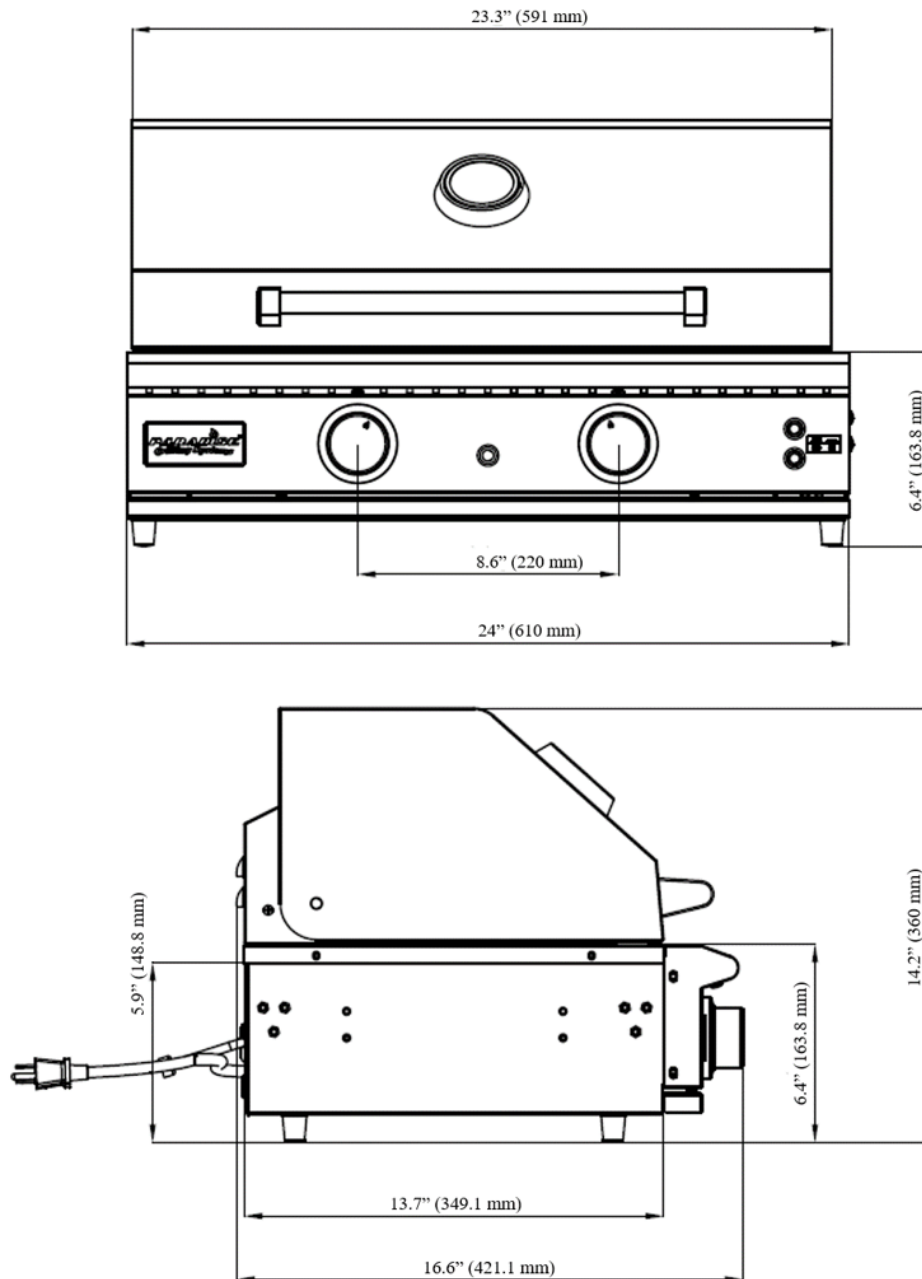



Figure 1 ESL-24 Dimensions

# Grill Assembly

Your ESL-24 Grill comes pre-assembled and requires very little setup. We do, however, recommend using professional help during the installation of your grill as improper installation may affect your warranty.

 <b>WARNING</b> 
<b>RISK OF FIRE:</b> The power cord must not be pinched against a sharp edge. Secure the cord to avoid tripping or snagging. To reduce the risk of fire, electric shock, or personal injury, do not run cord under carpeting, and do not cover cord with throw rugs or runners. Arrange the cord away from traffic areas to avoid tripping hazards.
<b>RISK OF FIRE:</b> Do not block air intake or exhaust in any manner. Do not place the grill on soft surfaces where opening may be blocked.
<b>RISK OF FIRE:</b> Do not blow or place insulation against the grill.
This electrical appliance is tested and listed for use only with the approved optional accessories. Use of accessories not specifically tested for this appliance could result in a safety hazard and/or void the warranty.
The grill is very heavy. It is highly recommended that two people lift this appliance.

---

## Electrical Precautions

The grill must be electrically ground in accordance with local codes or, in the absence of local codes, with the National Electrical Code, ANSI/NFPA 70, or the Canadian Electrical Code, Part 1, CSA C22.1.

This electrical appliance is equipped with a grounded, 3-pronged plug for protection against shock hazard. Plug this appliance into a properly grounded, 3-prong GFCI protected receptacle on a dedicated 20-amp circuit. DO NOT cut or remove the grounding prong from the plug.

Follow these precautions if an extension cord is used to connect the grill island to an electrical supply:

- Use only 12-gauge extension cords with a 3 prong grounding plug, rated for the equipment power, and approved for outdoor use with a W-A marking on the tag
- When connecting, first connect plug to the outdoor cooking appliance then plug appliance into the outlet
- To protect against electrical shock, never immerse cord or plugs in water or other liquid
- Unplug the appliance from the outlet when not in use and before cleaning

- Do not operate the grill with a damaged cord, plug, or after the appliance malfunctions or has been damaged in any manner; contact Paradise Grills to discuss service options, or call a licensed professional for inspection and repair
- The cord should be arranged so that it will not drape over the countertop or tabletop (where it can be pulled on or tripped over)
- Do not let the cord hang over any sharp edge or touch any hot surfaces
- Do not run the power cord directly below the appliance
- Never remove the grounding plug or use with a 2-prong adapter

---

## Unpack the Box

1. Open the box and remove the Styrofoam spacers
2. Remove the grill from the box and place on a solid surface; two people are needed for lifting
3. Remove the plastic wrap, cardboard spacers, and zip ties from the outside of the grill
4. Remove the white shipping cover and set aside
5. Open the grill lid and remove all plastic wrap, zip ties, and straps



*Figure 2 Unpack the Grill*

6. Remove and retain these accessories:
  - Operator Manual
  - Side shelves and handles
  - LED light power supply
  - Warming rack
7. Check the grill and all components for any damage

---

# Install the Grill

## Countertop Placement

The grill base must be placed on a stable, level surface to ensure the grill remains stable and upright at all times. Place the grill on a countertop surface as follows:

1. Place the grill on a clean, dry, level, non-combustible surface
2. Ensure that all clearance and location requirements on page 7 are met
3. Route power cord to electric outlet ensuring the cord does not and cannot come into contact with any heat source and does not have any pinch points

**NOTE:** The ESL-24 can be taken to and used at any **outdoor** location with a stable surface to support the grill, adequate ventilation, and a suitable power supply, such as at a park or campground.

## Pedestal Installation (optional)

The pedestal has four major components to assemble – Grill platform, Column, Base, and Mounting plate – as shown in Figure 3. Dimensions of the grill mounted to a pedestal are in Figure 9.

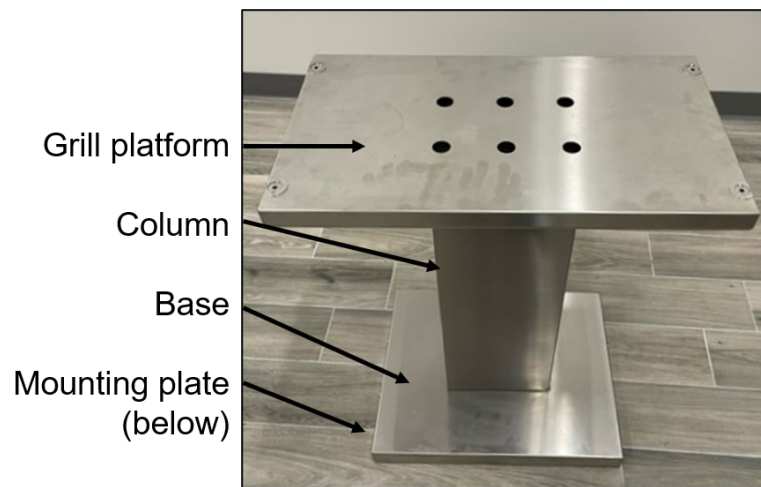

Figure 3 Pedestal Components



BEFORE USE, the grill base must be securely fastened to a stable, level surface to ensure the grill remains fixed and upright at all times.

The optional pedestal includes hardware to secure the mounting plate to a concrete or wooden floor surface (Figure 4). Use the hardware most appropriate for your installation surface to install the pedestal.

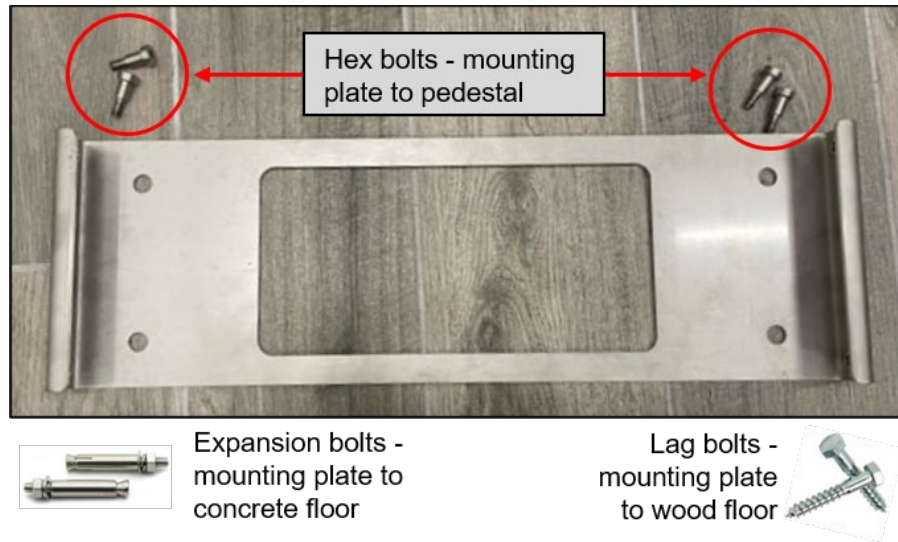

Figure 4 Pedestal Mounting Hardware

Complete these steps to assemble the pedestal:

1. Use an Allen head wrench to remove the four hex head bolts from the sides of the base (Figure 7 A) to release the mounting plate (Figure 7 B)
2. Securely attach the mounting plate to the installation ground surface using the most appropriate hardware for the material below the pedestal
  - a. If mounting to a concrete or brick surface:
    - i. Locate the patio mount base in the planned installation location and mark the 4 holes on the surface
    - ii. Drill the marked holes to a 1/2" diameter x 2" depth

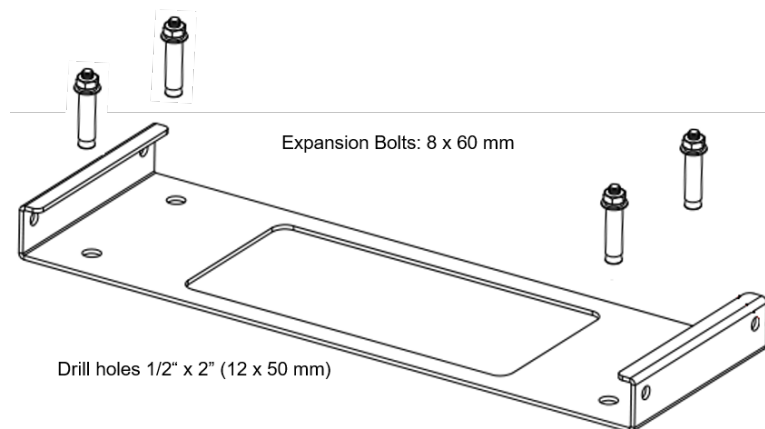

Figure 5 Expansion Bolt Installation

- iii. Insert expansion bolts into the holes and ensure that they are flush with the ground; remove the screws
- iv. Align the patio mount base holes over the lag shields in the ground
- v. Secure the base with the expansion bolt screws

b. If mounting to a wooden floor:

- i. Locate the patio mount base in the planned grill location and mark the 4 holes on the surface
- ii. Drill the marked holes with 1/4" drill bit about 1.5" deep
- iii. Align the patio mount base holes over the holes drilled in the wood

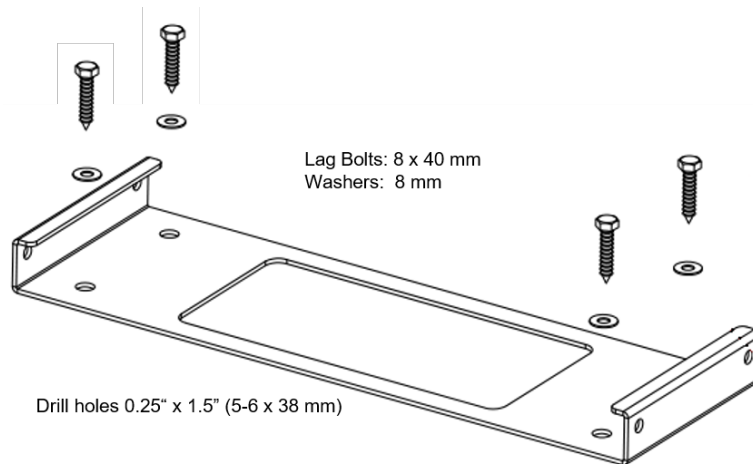

Figure 6 Lag Bolt Installation

iv. Use a socket wrench to secure the base with the washers and lag bolts

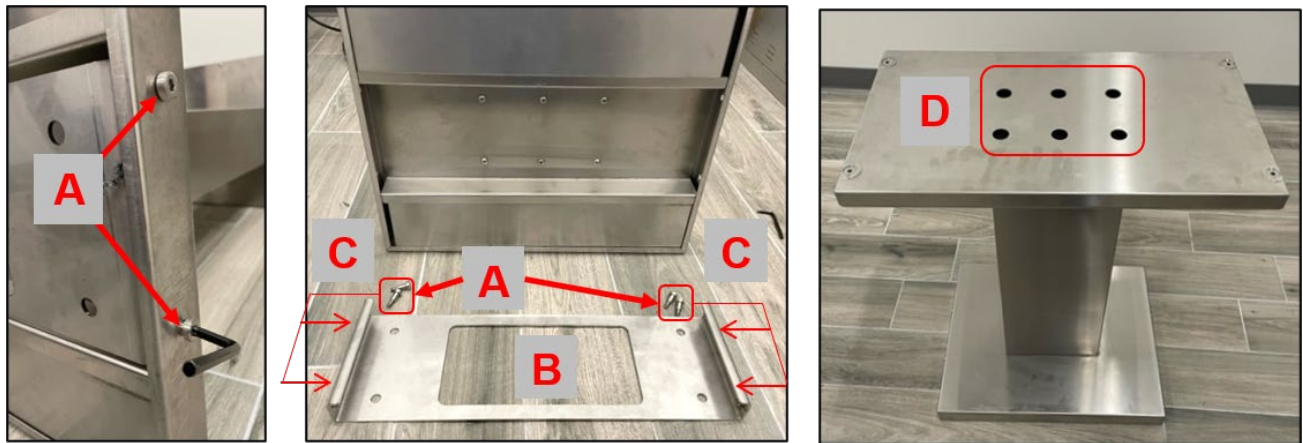

Figure 7 Attach the Base to Pedestal

3. Lift pedestal assembly onto the mounting plate and align the holes on each side
4. Use an Allen head wrench to secure the pedestal to the mounting plate using the four hex head bolts (Figure 7 C)
5. Position the grill platform onto the top of the pedestal
6. Align the six holes in the grill platform with the bolt holes in the top of the column; reach through the larger holes in the upper surface to attach using the provided bolts (Figure 7 D)
7. Remove the drip tray
8. Remove the four rubber feet from the bottom of the grill:

- a. Remove the plug from the center of each foot (Figure 8 left)
- b. Use a Phillips head screwdriver to remove the screw
9. Position the grill onto the platform aligned with the screw holes (Figure 8 center)

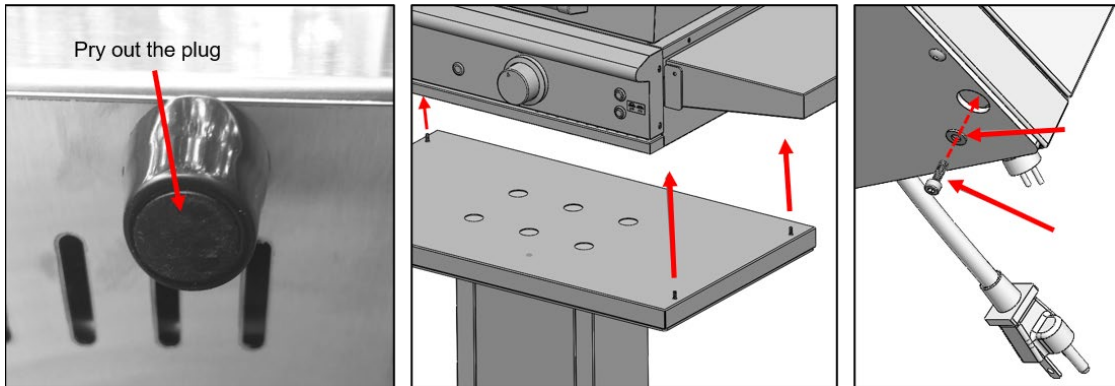

Figure 8 Attach Grill to Platform

10. Insert four mounting screws and washers through the large holes to the top surface, through the feet, and into the grill screw holes (Figure 8 right)
11. Tighten the mounting screws
12. Replace the drip tray

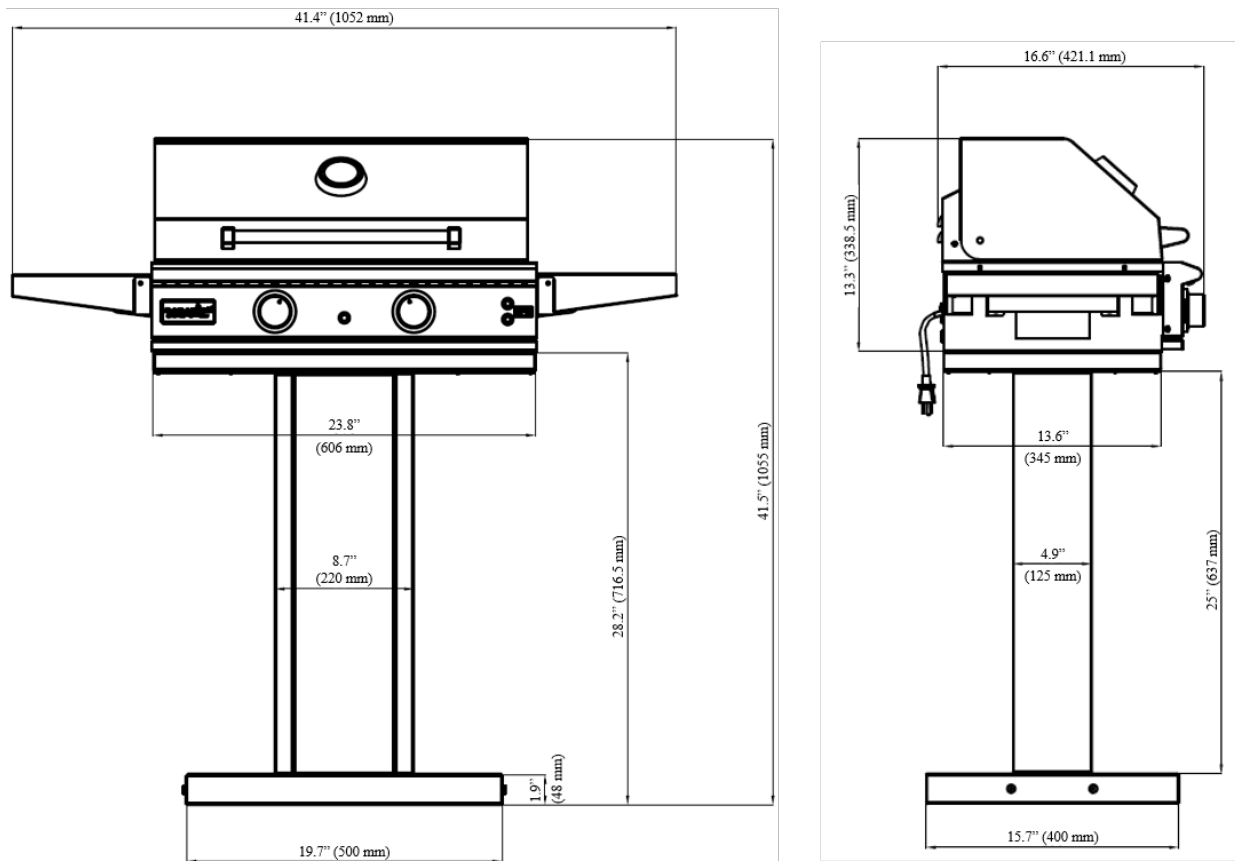

Figure 9 Pedestal and Grill Dimensions

## Paradise Grills Grill Cart (optional)

A Grill Cart that supports the ESL-24 Electric Grill is available for purchase. A shelf sleeve, shown in Figure 10, is required for the ESL-24. To install:

1. Assemble the Grill Cart per the included instruction sheet
2. Insert the shelf sleeve into place in the cutout:

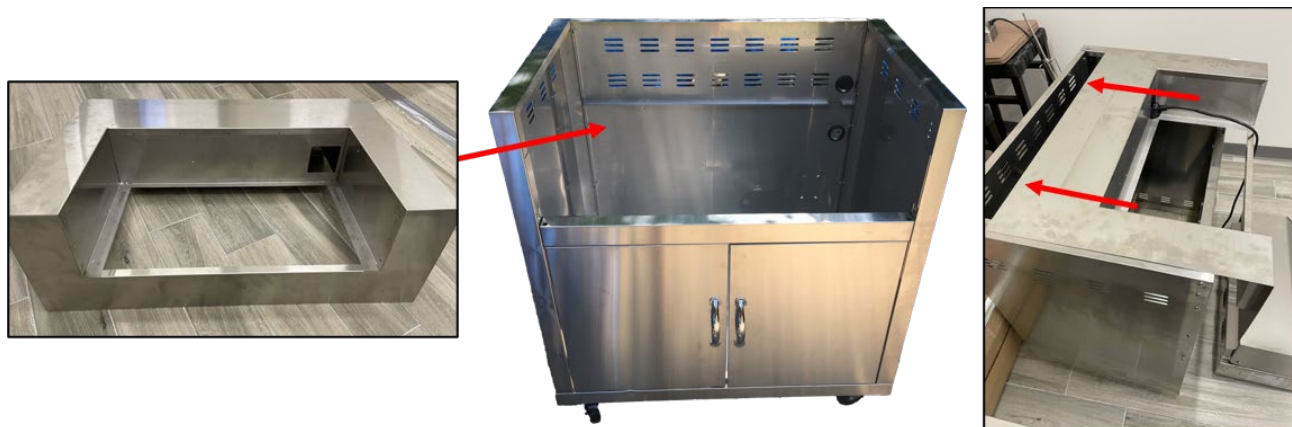

Figure 10 Install Shelf Sleeve into Grill Cart

3. Carefully snip the zip ties around the electrical cable at the right rear corner of the grill (Figure 11); DO NOT CUT THE WIRE

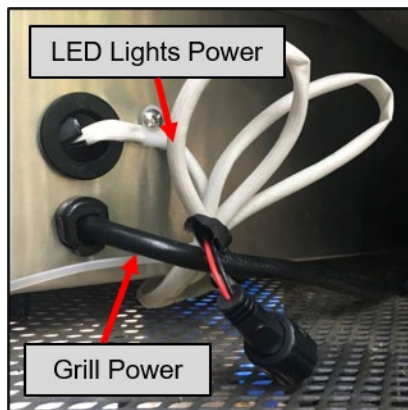

Figure 11 Electrical Cables

4. Connect the grill's LED lights electrical cable to the power supply:

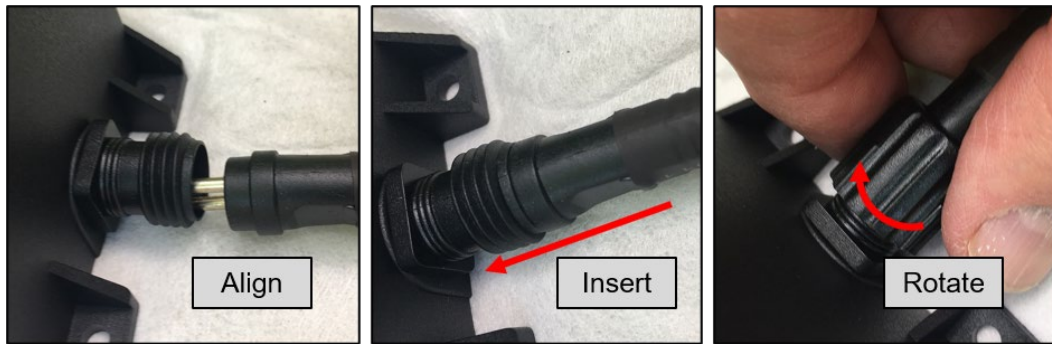

Figure 12 Connect Power Supply

- a. Align the grill plug with the power supply holes (Figure 12 left)
  - b. Insert the plug until it is fully seated (Figure 12 center)
  - c. Slide the gnarled locking nut to the threads and hand-tighten until it stops; do not force
5. Gather the electrical cords and feed them into the power cord access at the rear of the sleeve



The grill is heavy. Lift using two people to avoid injury and damage to the grill and island.

Pinch Hazard! Do not allow fingers to become pinched between grill and counter top.

6. Lift the grill into place; use two people for safety:
- a. Position the grill into the cut-out so it is 1/3 to 1/2 way into the cut-out with the outside edge resting on the cut-out edge
  - b. Ensure the electrical cables are fed into the power cord access
  - c. Ensure nothing is binding below the grill
  - d. Slide the grill into place in the cut-out so the grill's front edge is aligned with the sleeve's front edge (Figure 13)



Figure 13 Place ESL-24 into Shelf Sleeve

7. Check to ensure the grill is level and properly supported around the entire outside edge of cut-out
8. If desired, attach the LED light power supply to the four mounting holes on the lower right corner inside the cart (Figure 14)

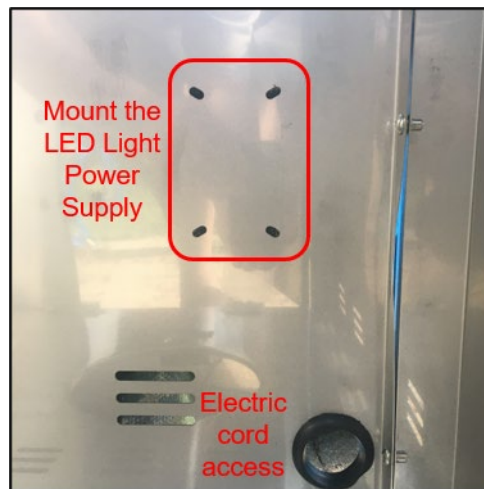

Figure 14 Mount the LED Light Power Supply

9. Use the hole at bottom right an extension cord, if desired

## Island Installation (optional)

### ***Paradise Grill Island***

The ESL-24 requires a shelf sleeve to fit into a Paradise Grills Island. The delivery and setup crew will install the sleeve and ESL-24 into the island

### ***Custom Built Base***

If installing the ESL-24 into a custom-built cabinet, a shelf sleeve is available for purchase from Paradise Grills to support the grill. Build an opening to fit the sleeve dimensions shown in Figure 15.

Otherwise, create a cutout to hold the ESL-24 per the dimensions shown in Figure 1. Leave an opening below the lip to ensure sufficient ventilation around the grill. The grill feet must rest on the support shelf.

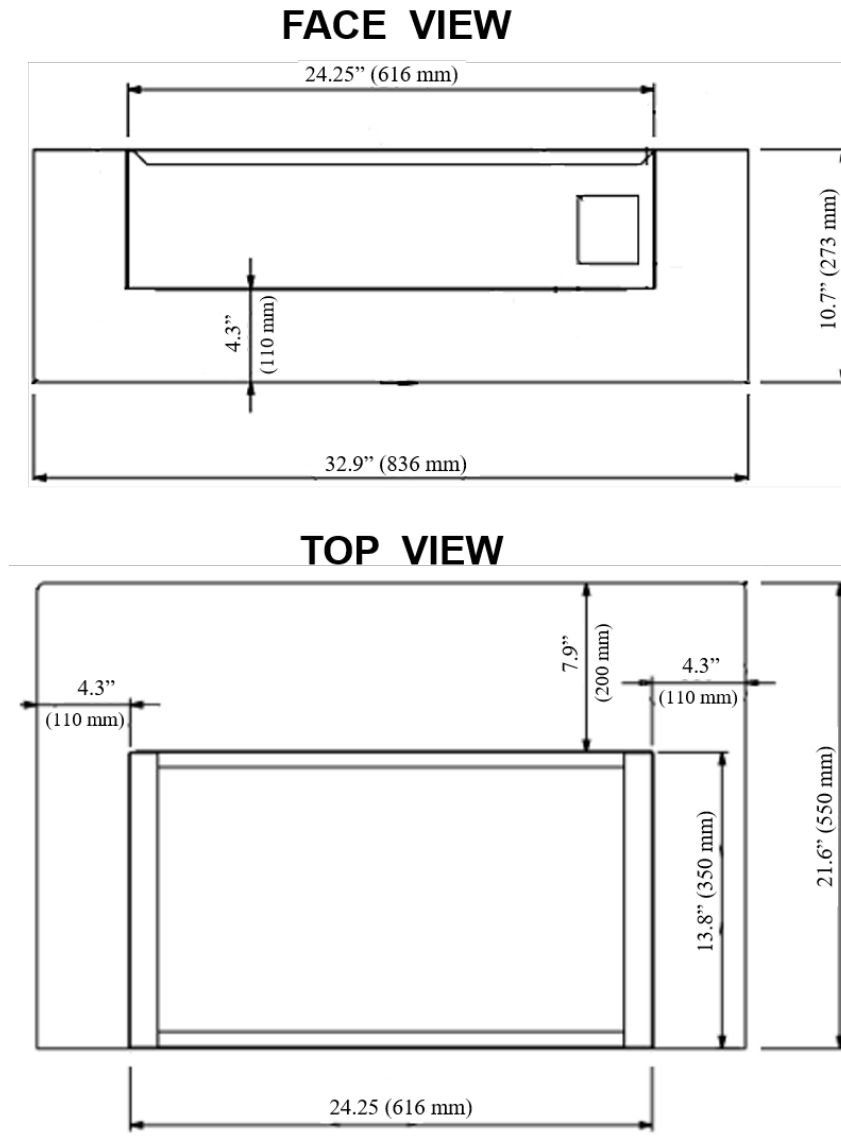

Figure 15 Shelf Sleeve Dimensions

---

## Grill Setup

### Basic Setup

Complete the grill setup with these steps:

1. Pull the drip pan out slightly and remove the protective covers from each side (Figure 16)



Figure 16 Drip Pan Protective Covers

2. Remove the grate from the grill, remove the plastic sleeve, and replace grate in the grill



Figure 17 Grate in Place

3. Remove plastic from the warming rack and fit onto the support on each side of the grill near the top



Figure 18 Insert Warming Rack

**NOTE:** Complete steps 4 and 5 if you did not install the grill into an Island.

4. Carefully snip the zip ties around the white electric cable at the right rear corner of the grill (Figure 19)

**NOTE:** DO NOT CUT THE WIRE; the black cable is the grill power cable.

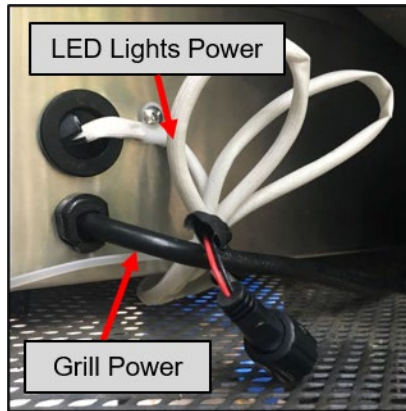

Figure 19 Electrical Cables

5. Connect the grill's LED lights electrical cable (white cable) to the power supply:

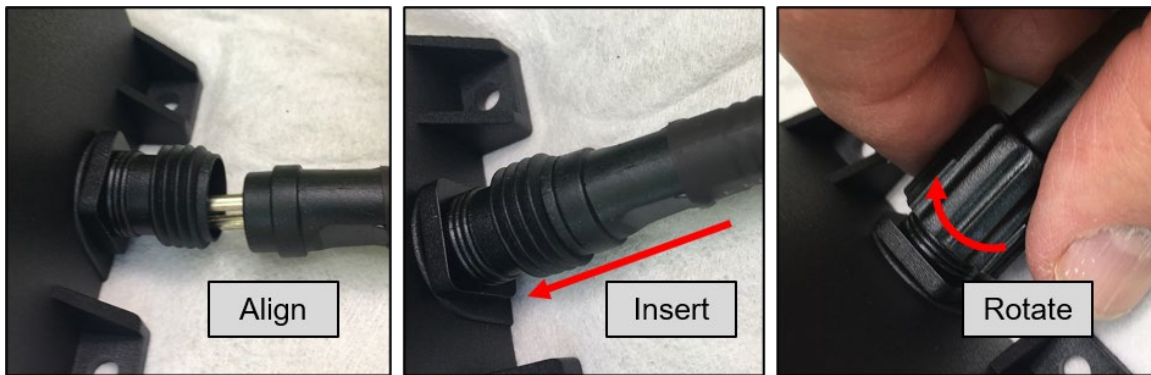

Figure 20 Connect LED Lights Power Supply

- a. Align the grill plug with the power supply holes (Figure 20 left)
  - b. Insert the plug until it is fully seated (Figure 20 center)
  - c. Slide the gnarled locking nut to the threads and hand-tighten until it stops; do not force
6. Plug in the LED lights power supply and test the lights:



Figure 21 LED Light Controls

- a. Two buttons to the right of the heating element control knobs switch the lights On and Off
- b. Press the top button to turn on the inside lights; press again to turn them off
- c. Press the bottom button to turn on the control knob lights; press again to turn them off

## Install Handles

Lifting handles may be installed if your grill is used on a countertop. Mounting holes are provided on each side of the grill for handles and shelves (Figure 22). Both sides are identical.

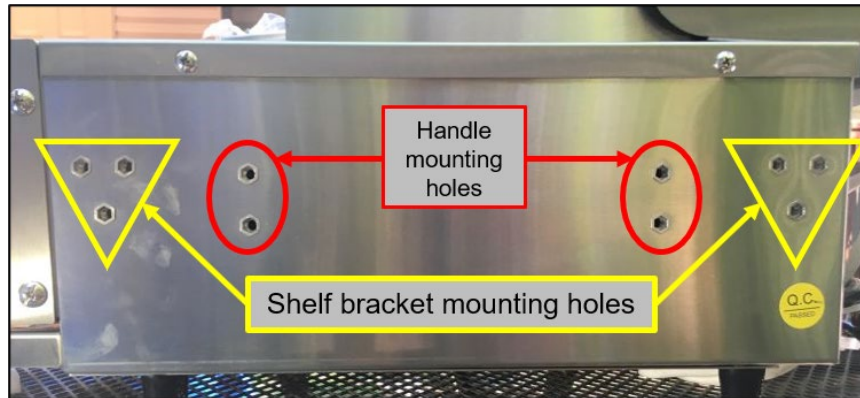

Figure 22 Handle and Shelf Mounting Holes

Install the handles as follows:

1. Align the handle with the handle mounting screws
2. Use a Philips head screwdriver to insert and start the top two screws



Figure 23 Install the Handle

3. Insert and start the bottom two screws until tight, then tighten the top two screws
4. Repeat for the other side of the grill

## Install Side Shelves

Side shelves may be installed if your grill is used on a countertop or is mounted to a pedestal. Mounting holes are provided on each side of the grill for handles and shelves (Figure 22). Both sides are identical. The shelves will fit over the handles, if installed, and may be raised or lowered.

Install the shelves as follows:

1. Locate the left (L) and right (R) brackets
2. Align the left bracket with the triangular pattern holes on the left side of the grill (Figure 24 left); use a Phillips head screwdriver to start all three screws, then tighten all three



Figure 24 Install Side Shelves

3. Repeat to install the right bracket
4. Position the shelf to insert the right-side bracket pin into the straight slot (Figure 25 left), and the left-side bracket pin into the T slot on the left shelf (Figure 25 right)

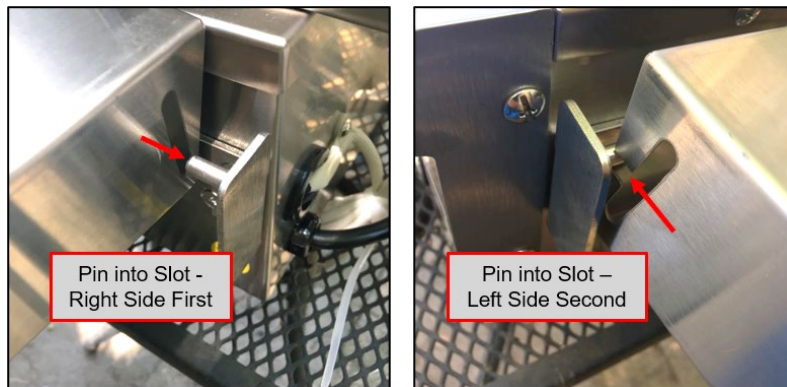

Figure 25 Fit Shelf to Brackets

5. Repeat for the other shelf
6. To lower the shelf, lift on both sides at the bracket end, then lower the outer edge; reverse to raise the shelf (Figure 26)

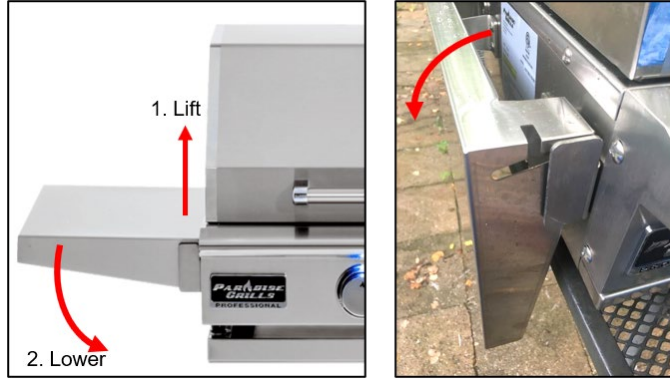

Figure 26 Lower the Side Shelf

# Operating the Grill

---

## Warnings and Cautions

 <b>WARNING</b> 
---

All grill surfaces will get hot during use. Use extreme caution when operating the grill. Do not touch hot surfaces. Always use the handle to open or close the grill.
--

Never cover grill slots, holes, or passages with aluminum foil or any other material. Doing so blocks air flow through the grill and may cause overheating.
---

Never cover 75% or more of the cooking or grill surface with aluminum foil or pans. Doing so may cause overheating of the electronic components and voids all warranties.
---

Do not operate this grill with air blowing into or across the rear grill lid vent. This can cause poor performance and/or dangerous overheating. Orient the grill so that any prevailing wind blows against the front of the grill.
---

 <b>CAUTION</b> 
---

Please read all instructions before installing or operating your electric grill to prevent injury and appliance damage.
---

Do not leave an operating grill unattended.
---

Close supervision is necessary when this or any appliance is used near children. Keep children away from the grill during operation and until the grill has cooled off.
---

Use barbecue tools with wood handles and insulated grill mitts when operating the grill.
--

Do not operate this appliance with a damaged cord or plug, or after a malfunction. Contact Paradise Grills to discuss service options, or call a licensed professional for inspection and repair.
---

## Normal Operation

Follow these steps to operate the grill:

1. Open the hood
2. Plug in the grill's power cord
3. Before each use, test the power cord inline surge protector (right) as follows:
  - a. With the grill plugged in the indicator should be ON (red)
  - b. Press the yellow TEST button – indicator should be OFF as shown at right
  - c. Press the red RESET button for use – indicator will be ON (red)
  - d. DO NOT USE GRILL IF TEST FAILS
4. Rotate the timer knob clockwise to activate the heating system (Figure 27)
5. Rotate the grill temperature knob either direction to HIGH (Figure 28)

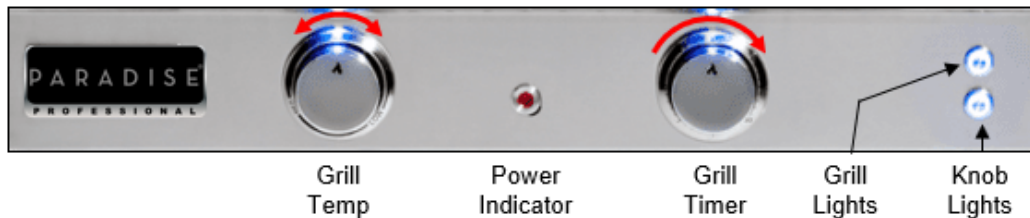
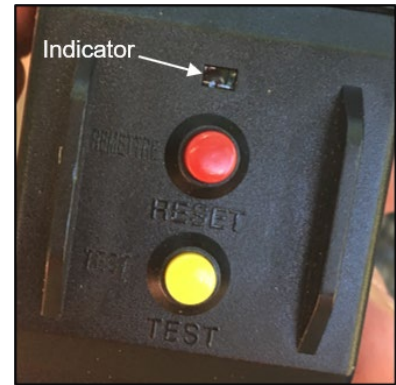

Figure 27 Grill Controls

6. Allow the grill to preheat for 5-10 minutes or until the grill reaches the desired temperature
7. To activate the grill lights, press either of the light buttons shown in Figure 27
8. Adjust the temperature setting as desired to HIGH, MED, or LOW (Figure 28); place food on the grill, and set the timer for the desired cooking time, up to 60 minutes

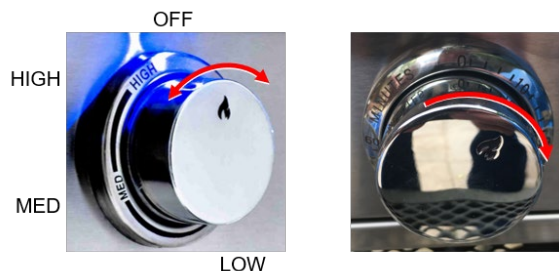

Figure 28 Heating Element Controls

9. When the timer expires the heating element will be unpowered and the power light will extinguish
10. Rotate the temperature knob to OFF, and unplug the grill's power cord when grilling is complete



---

## Using the Grill

### First Time Operation

Before cooking with your grill for the first time, operate the grill on HIGH for five minutes to burn off any foreign matter and rid the grill of any odors.

### Heating Element

 <b>WARNING</b> 
Do not leave the grill unattended when operating.
This grill can reach very high temperatures with the heating elements on HIGH; burning fat or grease may result in extreme temperatures that may result in personal injury or damage to the grill and voids all warranties.
All grill components are subject to warping due to excessive temperature. Any such warping is not covered by warranty.

Preheat the grill before cooking on HIGH for five minutes with the hood closed. For normal grilling:

- Use HIGH setting for heavy cooking and cleanup
- Use other settings to create temperatures to suit your personal cooking preferences
- Temperatures will vary with outside temperatures and wind conditions
- Monitor the grill thermometer (right) to avoid an excessive temperature situation.

If temperature exceeds 400° F, rotate the temperature control knob to OFF. Step away from the grill and allow it to cool.

If there is a fire in the grill enclosure and it's safe to do so:

- Turn the temperature knob to OFF and the timer to zero
- Remove the food and douse the flames with baking soda, sand, or kosher salt
- Use a fire extinguisher if available
- Close the lid and any grill vents to further starve the fire of oxygen
- **NEVER USE WATER** to extinguish a grease fire or flare up



# Cleaning and Maintenance

---

## Maintain your Grill

PROTECT YOUR INVESTMENT! Stainless steel products are **not self-cleaning**. The #304 stainless steel used in the construction of your grill is rust and corrosion **resistant**, not rust and corrosion **proof**. Follow the instructions in this manual to properly maintain your product for years of enjoyment.



---

## Stainless Steel Maintenance

STAINLESS STEEL MUST BE CLEANED AND MAINTAINED.

You must regularly clean the grill's stainless steel to preserve corrosion resistance and aesthetics. A thin layer of chromium oxide protects stainless steel from corrosion. Oxygen from the atmosphere combines with the chromium in the stainless steel to form a protective chromium oxide film. This protection will be reduced by any contamination of the surface by corrosive agents, such as dirt, fertilizers, chlorine, pesticides, high salt content air and or other corrosive substances. Any contamination of the surface by dirt, or other material, hinders this passivation process and traps corrosive agents reducing corrosion protection. Regular cleaning is necessary to preserve the stainless steel's appearance and integrity.

Routinely wipe down the exterior and interior of the grill to remove grease and splatters. Use a good stainless steel cleaner to clean and polish the exterior surfaces. Doing so on a regular basis minimizes the

amount of effort required to maintain the stainless steel. **DO NOT clean the grill while it is still hot!** For best results and longevity, routinely have a professional barbecue cleaning company detail the grill. After each use wipe down the exterior of the grill to remove grease and splatters.

To remove stubborn stains:

- DO NOT use metallic abrasives
- Use a good stainless-steel cleaner and non-abrasive microfiber towel or pad
- Always rub in the direction of the stainless steel's grain
- Read the product's label before using; some household cleaning products are not suitable for use on stainless steel
- Always start with the mildest cleaning solution first, rubbing in the direction of the grain
- Grease specks may gather in stainless steel's grain and bake onto the surface, giving the appearance of rust
- Some areas of the grill may discolor from the intense heat given off by the heating element, which is normal and cannot be cleaned off. For light and heavy food stains, use the products and processes described above

---

## Corrosive Environmental Conditions

The #304 stainless steel materials used in the construction of your grill are rust and corrosion **resistant**, not rust and corrosion **proof**. If neglected and left on the grill, corrosive elements (such as chlorine in the air, high salt content air, fertilizers, pesticides, corrosive cleaning solutions, and masonry dust and debris) may cause the stainless steel to develop surface oxidation, rust, corrosion, and pitting. To minimize such issues:

- Regularly wipe down the grill's stainless steel with a damp cloth or non-abrasive micro-fiber towel
- Allow the surfaces to dry before covering the grill. Do not cover a damp grill
- Apply a rust inhibitor which leaves a microscopic protective layer on the stainless steel
- For seasonal storage, use the process and products referred to above, and once the grill is dry, cover and secure the grill to minimize the amount of damp air getting to the surfaces

---

## Grill Exterior

Routinely wash with warm soapy water, and apply a good stainless steel polish to protect the grill exterior. Keep the grill covered when not in use.

---

## Grill Interior

- After cooking, burn off excess food debris and marinades for 5-10 minutes
- Once the grill is cooled down, thoroughly wipe down the cooking surface with a damp cloth. When dry, apply a light coat of vegetable oil or non-stick cooking spray
- Use an approved stainless-steel cleaner to remove grease build up, then rinse with clean water
- Routinely have a professional barbecue cleaning company detail the grill for best results and longevity
- DO NOT flood a hot cooking surface with cold water – doing so may cause the grill to warp or crack

---

## Cleaning the Drip Tray

The drip tray should be cleaned after each use. Failure to do so could result in a fire. After the grill is cooled down, remove the drip tray by pulling it out from the grill.



Figure 29 Drip Tray

Clean the drip tray with a clean cloth and hot soapy water, or an oven-style cleaning product. Replace, ensuring the tray is completely installed in the grill housing.

When using an oven-style cleaning product, follow the product's instructions. Many such cleaners are toxic and can damage the stainless-steel finish if not used properly.

If the grill was uncovered during rain, check the drip tray to drain any standing water.

---

## Preventive Maintenance

Replacement parts are available from Paradise Grills International, Inc. Contact us at 800-604-2023 for assistance.



Beyond removing and cleaning the cooking grate, flame tamers, and drip pan, there are no customer serviceable components in the ESL-24 electric grill. Any required repairs must be performed by a licensed electrician.

To ensure safe grill operation conduct the following inspections at least twice a year:

- Ensure grill area is clear and free from combustible materials, gasoline and other flammable vapors and liquids
- Ensure an unobstructed flow of combustion and ventilation air within the grill
- Inspect all electrical outlets and extension cords for wear, tear, cuts, or other damage, and replace as needed

# Parts Diagram

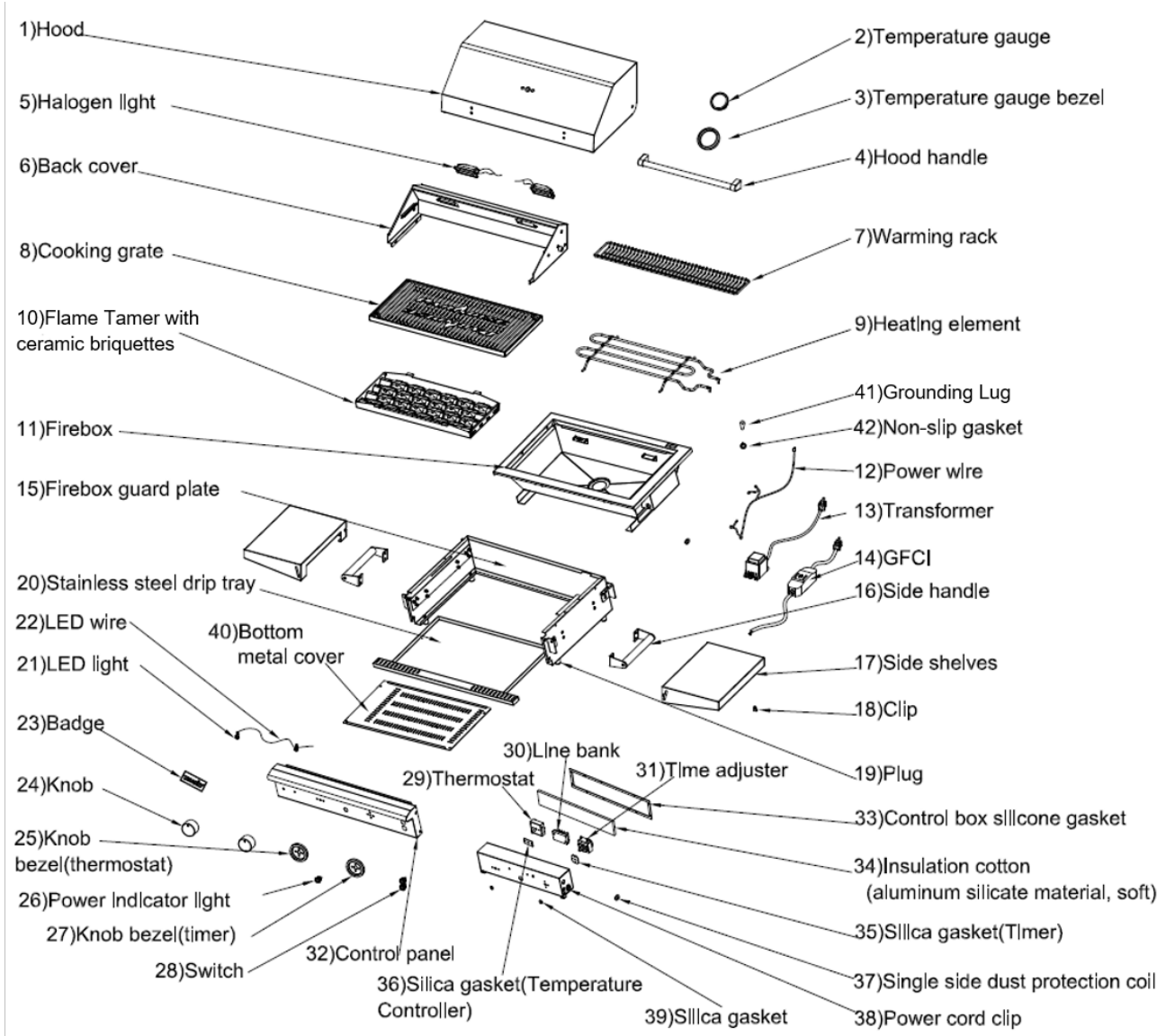

# Limited Manufacturer's Warranty

---

## Limited Warranty

Your grill (the “product”) is warranted to the ORIGINAL PURCHASER that it is free of original manufacturing defects from the date of purchase as follows:

- (i) limited lifetime warranty on structural integrity of stainless steel construction to be free from original manufacturing defects;
- (ii) two (2) years on cooking grate and flame tamers to be free from original manufacturing defects or burn-through; and
- (iii) one (1) year on heating element, heating element components, and lighting systems to be free from original manufacturing defects (collectively, the “Limited Warranty”).

This Limited Warranty is:

- (i) limited to the ORIGINAL PURCHASER at original site of delivery;
- (ii) limited to original manufacturing defects only; and
- (iii) limited to the shipment of replacement parts when covered by warranty

### **THIS LIMITED WARRANTY EXCLUDES ON-SITE SERVICE CALLS, LABOR, AND LABOR-RELATED COSTS.**

This Limited Warranty is void upon the ORIGINAL PURCHASER’S transfer of ownership of the product to any other person or entity.

This Limited Warranty excludes and does not cover:

- (1) oxidation, rust, corrosion, discoloration, staining, or other cosmetic issues; or
- (2) damage, deterioration, or warping related to or resulting from, in whole or in part:
  - (a) improper installation or operation, neglect, failure to maintain, misuse, commercial use, abuse, alteration, infestation, vandalism, accident, extreme environments, grease fires, or exposure to high cooking temperatures.
  - (b) severe weather conditions such as hail, earthquake, hurricane, snow, windstorm, tornado, micro/microburst, or heavy rainfall;
  - (c) corrosive conditions such as chlorine in the air, high salt content air, fertilizers, pesticides, corrosive cleaning solutions, or masonry dust and debris; or

The ORIGINAL PURCHASER is responsible for the safe and proper installation, usage, maintenance, servicing and cleaning of the product in accordance with all instructions in this Operator Manual.

For shipped products, immediately inspect your product upon receipt and inform the delivery company of any visible damage and ensure such damage is noted on the delivery receipt or freight bill and signed by the person making the delivery. File your written claim for damages immediately with the delivery company, regardless of

the extent of damage. Paradise Grills International, Inc. and/or Paradise Grills Direct, Inc. (collectively, "Paradise Grills") shall not be liable for any damage that occurs during shipment. If damages are unnoticed until the product is unpacked, immediately notify the delivery company and file a written concealed damage claim with them. This must be done within (5) days of the delivery date. Be sure to keep the box and shipping materials for inspection. All out-of-box claims must be made prior to installation. Any product installed in a damaged condition shall be conclusively deemed to have been damaged during installation and not covered under warranty.

**THIS LIMITED WARRANTY IS THE ORIGINAL PURCHASER'S SOLE AND EXCLUSIVE WARRANTY. THERE ARE NO WARRANTIES WHICH EXTEND BEYOND THE DESCRIPTION ON THE FACE HEREOF. ALL OTHER EXPRESS OR IMPLIED WARRANTIES ARE FULLY DISCLAIMED. THERE ARE NO EXPRESS WARRANTIES OTHER THAN THOSE LISTED AND DESCRIBED ON THE FACE OF THIS LIMITED MANUFACTURER'S WARRANTY. NO WARRANTIES, WHETHER EXPRESS OR IMPLIED, INCLUDING, BUT NOT LIMITED TO, ANY IMPLIED WARRANTIES OF MERCHANTABILITY OR FITNESS FOR A PARTICULAR PURPOSE SHALL APPLY. NO OTHER EXPRESS OR IMPLIED WARRANTY OR GUARANTY GIVEN BY ANY PERSON OR ENTITY WITH RESPECT TO THIS PRODUCT SHALL BE BINDING ON PARADISE GRILLS.**

Paradise Grills shall not be liable to the ORIGINAL PURCHASER (or any other person or entity) for any incidental, indirect, special, reliance, general, ordinary, nominal, pain and suffering, lost profits, exemplary, general, punitive, or consequential damages that are in any way based upon, related to, or arising from the product, either in whole or in part, regardless of the legal theory on which the claim is based (including without limitation, claims based on negligence, gross negligence, breach of warranty, statutory liability, regulatory liability, strict liability, contract, third-party liability or any other theory of law), and even if Paradise Grills has been advised of the possibility of such damages. The maximum liability of Paradise Grills to the ORIGINAL PURCHASER (or any other person or entity) in any way based upon, related to, or arising from the product, either in whole or in part, shall not exceed the total amount paid for the product by the ORIGINAL PURCHASER.

**No oral or written representation or commitment given by anyone, including but not limited to, an employee, representative, agent or affiliate of Paradise Grills shall in any way create a warranty (express, implied or otherwise) or in any way increase the scope of this express Limited Warranty.** If there is any inconsistency between this Limited Warranty and any other agreement or statement included with or relating to the grill, the terms of this Limited Warranty shall govern and control. If any provision of this Limited Warranty is found invalid or unenforceable by a court of competent jurisdiction, it shall be deemed modified to the minimum extent necessary to make it enforceable and the remainder of the Limited Warranty shall remain valid and enforceable according to its terms.

This Limited Warranty gives you specific legal rights; you may have other rights which vary by state.

---

## Warranty Claim Submission

The ORIGINAL PURCHASER must submit to Paradise Grills International, Inc. a warranty claim within five (5) business days of date such claim is or should have been discovered, or else such claim is forever waived and barred.

To submit a warranty claim, the ORIGINAL PURCHASER must submit a written description and photographs detailing the grill's damage or defect(s), along with a complete copy of the Final Sales Agreement either:

- (i) via email to [Warranty.Claim@paradisegrills.com](mailto:Warranty.Claim@paradisegrills.com); or
- (ii) via U.S. mail to Paradise Grills International, Inc., Attn: Warranty Claim, 640 Ocoee Business Parkway, Suite 80, Ocoee, Florida 34761.

For more information, please call Paradise Grills International, Inc. at 800-604-2023.